

Product datasheet

HeatMax™ manifold

Manufactured in Germany, individually pressure tested, and produced to the highest standards. These are not low-cost welded or extruded manifolds for one simple reason: we demand the best for the heart of the system.

The HeatMax™ manifold distributes water around the underfloor heating zones within the floor. It is supplied with all the ball valves and bleed points for an easy install.

The flow rate to each loop can be regulated and balanced by individual zone valves, and motorised actuators can be fitted to maintain a comfortable temperature in each zone.



Features:

- CrystalClear™ flow meters
- Stainless steel
- Flat-sealing male thread on both sides
- Low installation depth
- Eurocone pipe connection
- Individually pressure tested
- Ready to mount with brackets
- Fully EN1264 compliant

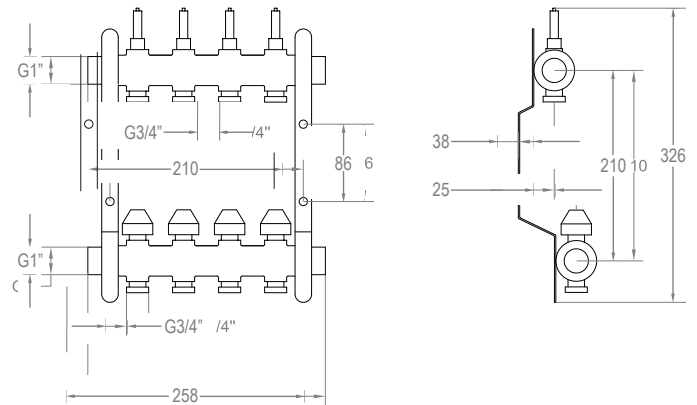

Technical:

- Distance between outlets: 50mm
- CrystalClear™ flow meters with shut off function and scale: 0-4L/min
- Heating circuit connection: 3/4" M with eurocone
- Manifold material: stainless steel
- Valves and fittings: brass CW614N / CW617N
- O-Rings: EPDM elastomers
- Washers: EPDM elastomers or aramid AFM34
- Ball seat: PTFE
- Brackets: steel, galvanized

Operating temperature and pressures:

- Operation temperature range: -10°C to 90°C
- Maximum operating pressure: 10 bar

About us

No ifs, no buts. The award-winning Continal® service means you get an underfloor heating system delivered to you on time, on site, every time, no compromise.

Manifold length						
Zones	2	3	4	5	6	7
Length (mm)	160	210	260	310	360	410

Manifold length					
Zones	8	9	10	11	12
Length (mm)	460	510	560	610	660

