

Product datasheet

HeatMax™ small area mixer

The HeatMax™ small area mixer has been designed for control of flow and water temperature to single rooms or to small areas less than 40m², where a manifold is not required.

Pre-assembled and tested to ensure that it can be fitted with the minimum of labour, and commissioned immediately once fitted.

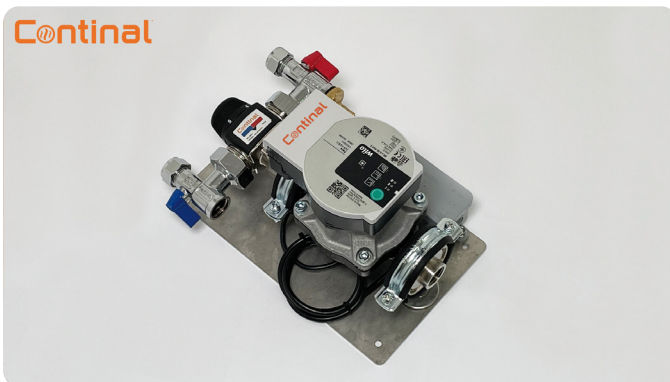

The HeatMax™ small area mixer is designed to connect to new and existing heating systems with 15mm compression connections for the flow and return.

Interlock with the existing heating system is achieved via the temperature switch, which only enables the pump to run when the heating system water is above 40°C. The TMV has been modified to allow bypass when the pump is not operational.

Technical:

- Dimensions: 245mm x 170mm
- Inlet connections: 15mm compression
- Outlet connections: to suit pipe diameter
- TMV body: kvs 1.3
- Valve body: kvs 3.4

Features:

- Compact design
- Nickel plated
- High performance pump
- Mounted pump control terminal box
- Pre-assembled and bracketed for simple mounting
- Built-in isolating valve in flow / return elbow
- Simple wiring

Temperature:

- Operating temperature range: 35°C to 60°C
- Maximum temperature: 95°C
- Temperature switch for pump control on inlet water temperature: 40°C

Pressure:

- Maximum static pressure: 10 bar
- Maximum differential pressure: 3 bar

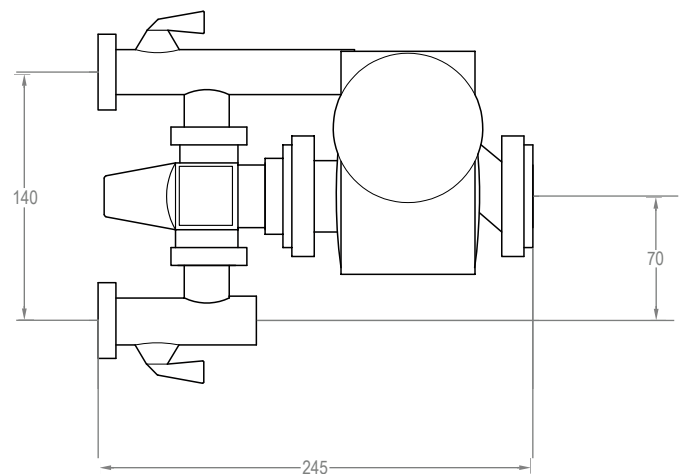

About us

No ifs, no buts. The award-winning Continal® service means you get an underfloor heating system delivered to you on time, on site, every time, no compromise.

